

## Connecting SRF04 Sonar Modules to the BX-24

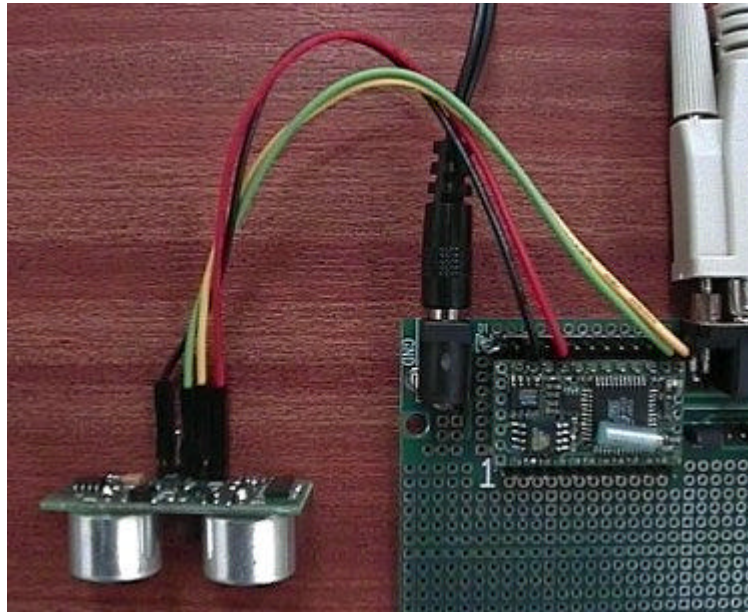

### Introduction

The SRF04 module is controlled by a trigger pulse from the BX-24 host controller of around 10 $\mu$ s duration. After receiving the trigger pulse, the SRF04 will raise its echo pulse and wait for a returning echo. As soon as the echo is detected by the SRF04, it will lower its echo line again. The BX-24 host controller will measure the width of the echo pulse and use this to calculate the range.

Although we have powered the SRF04 from the BX-24 in the photo above, the BX-24's internal 5v regulator is not suitable for powering much external circuitry. It will power a single SRF04 OK, but anything more and I would recommend you use a separate 5v regulator as shown in the schematic below. Further SRF04's can be connected, not shown here, with each SRF04 requiring its own input and output pins.

### Circuit Schematic for connecting an SRF04 Sonar Module to the BX-24

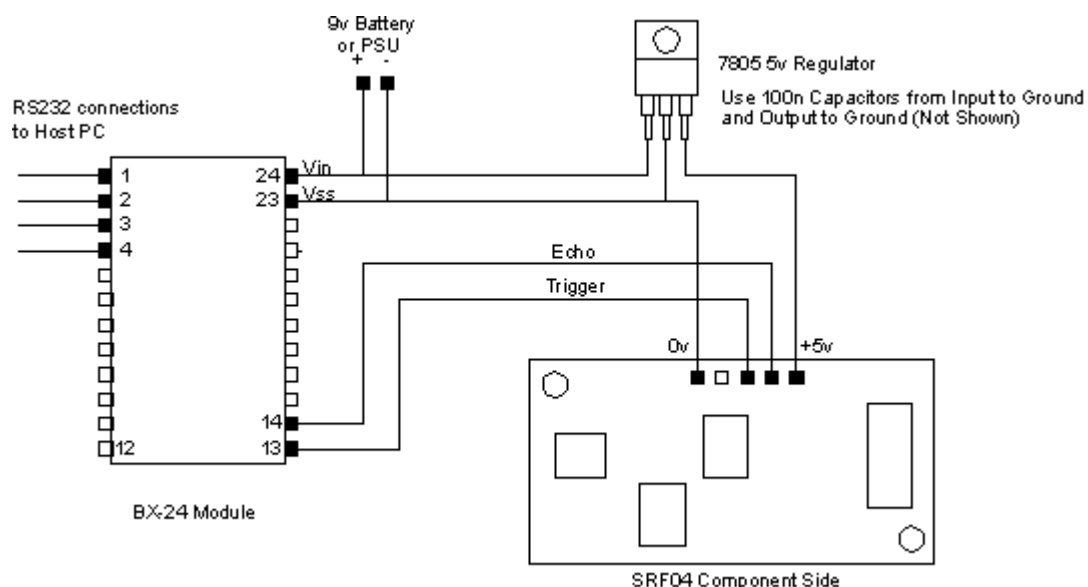

The following code can be downloaded [here](#)

```
*****
***                               **
***   SRF04 Demonstration Software for the BX-24   **
***                               **
***           Copyright 2002 - Devantech Ltd       **
***   Commercial use of this software is prohibited **
***   Private and educational use only is permitted **
***                               **
***           Written by Gerald Coe - February 2002 **
***                               **
*****

Sub Main()
  Const EchoPin As Byte = 14           ' Define which pins you want to use here
  Const TrigPin As Byte = 13
  Dim Range As Integer

  Call PutPin(EchoPin, bxInputTristate)
  Call PutPin(TrigPin, bxOutputLow)
  do
    Call PulseOut(TrigPin, 10, 1)      ' 10uS Trigger pulse
    Range = PulseIn(EchoPin, 1) \ 54   ' use 54 for Cm or 137 for Inches
    Debug.Print "Range is "; CStr(Range)
    Call Delay(0.1)                    ' 100mS to next ping (minimum is 10mS)
  loop
End Sub
```

You can find more information on the SRF04 [here](#)